

TIMELESS INSTRUMENTS

# VIEWLINE 52MM INSTRUMENTS

INSTRUCTIONS MANUAL  
rev. AA



EN

DE

IT

FR

ES

PT

# CONTENT

|                         |    |
|-------------------------|----|
| Part Numbers            | 3  |
| Safety Information      | 6  |
| Mechanical Installation | 8  |
| Electrical Installation | 12 |
| Technical Data          | 19 |
| Accessories             | 20 |

# PART NUMBERS

## COOLANT TEMPERATURE

| Part Number                | Dial Color     | Dial Scale (outer / inner) | Sensor Input   |
|----------------------------|----------------|----------------------------|----------------|
| A2C59514170<br>A2C59514237 | Black<br>White | 120 °C / 250 °F            | 287.4 – 22.7 Ω |
| A2C59514176<br>A2C59514241 | Black<br>White | 250 °F / 120 °C            | 287.4 – 22.7 Ω |

## ENGINE OIL TEMPERATURE

| Part Number                | Dial Color     | Dial Scale (outer / inner) | Sensor Input   |
|----------------------------|----------------|----------------------------|----------------|
| A2C59514160<br>A2C59514231 | Black<br>White | 150 °C / 300 °F            | 322.8 – 18.6 Ω |
| A2C59514165<br>A2C59514234 | Black<br>White | 300 °F / 150 °C            | 322.8 – 18.6 Ω |

## BOOST PRESSURE

| Part Number                | Dial Color     | Dial Scale (outer / inner) | Sensor Input |
|----------------------------|----------------|----------------------------|--------------|
| A2C59514149<br>A2C59514225 | Black<br>White | 2 bar / 30 psi             | 10 – 184 Ω   |

## ENGINE OIL PRESSURE

| Part Number                | Dial Color     | Dial Scale (outer / inner) | Sensor Input |
|----------------------------|----------------|----------------------------|--------------|
| A2C59514123<br>A2C59514211 | Black<br>White | 5 bar / 80 psi             | 10 – 184 Ω   |
| A2C59514128<br>A2C59514214 | Black<br>White | 80 psi / 5 bar             | 10 – 184 Ω   |
| A2C59514111<br>A2C59514199 | Black<br>White | 10 bar / 150 psi           | 10 – 184 Ω   |
| A2C59514202                | White          | 150 psi / 10 bar           | 240 – 33.5 Ω |

## TRANSMISSION OIL PRESSURE

| Part Number                | Dial Color     | Dial Scale (outer / inner) | Sensor Input |
|----------------------------|----------------|----------------------------|--------------|
| A2C59514136<br>A2C59514206 | Black<br>White | 25 bar / 350 psi           | 10 – 184 Ω   |
| A2C59514141<br>A2C59514208 | Black<br>White | 30 bar / 435 psi           | 10 – 184 Ω   |
| A2C59514145<br>A2C59514223 | Black<br>White | 400 psi / 25 bar           | 10 – 184 Ω   |
| A2C1278230001              | Black          | 10 bar                     | 0 – 5 V      |
| A2C1278250001              | Black          | 30 bar                     | 0 – 5 V      |

## FUEL LEVEL

| Part Number                | Dial Color     | Dial Scale (outer / inner) | Sensor Input |
|----------------------------|----------------|----------------------------|--------------|
| A2C59514085<br>A2C59514186 | Black<br>White | E – F                      | 0 – 90 Ω     |
| A2C59514082<br>A2C59514184 | Black<br>White | 0 – 1/1                    | 3 – 180 Ω    |
| A2C59514094<br>A2C59514190 | Black<br>White | E – F                      | 240 – 33.5 Ω |
| A2C59514079<br>A2C59514182 | Black<br>White | 0 – 1/1                    | 90 – 4 Ω     |
| A2C59514088<br>A2C59514188 | Black<br>White | E – F                      | 90 – 4 Ω     |

## FRESH WATER LEVEL

| Part Number                | Dial Color     | Dial Scale (outer / inner) | Sensor Input |
|----------------------------|----------------|----------------------------|--------------|
| A2C59514676<br>A2C59514677 | Black<br>White | 0 – 1/1                    | 4 – 20 mA    |
| A2C59514097<br>A2C59514192 | Black<br>White | 0 – 1/1                    | 3 – 180 Ω    |
| A2C59514099<br>A2C59514193 | Black<br>White | E – F                      | 3 – 180 Ω    |

## WASTE WATER LEVEL

| Part Number                | Dial Color     | Dial Scale (outer / inner) | Sensor Input |
|----------------------------|----------------|----------------------------|--------------|
| A2C59512342<br>A2C59512343 | Black<br>White | 0 – 1/1                    | 4 – 20 mA    |

## EXHAUST GAS TEMPERATURE

| Part Number                | Dial Color     | Dial Scale (outer / inner) | Sensor Input |
|----------------------------|----------------|----------------------------|--------------|
| A2C59512332<br>A2C59512333 | Black<br>White | 900 °C / 1650 °F           | 37 mV        |
| A2C59512334<br>A2C59512335 | Black<br>White | 1650 °F / 900 °C           | 37 mV        |

## VOLTMETER

| Part Number                | Dial Color     | Dial Scale (outer / inner) | Sensor Input |
|----------------------------|----------------|----------------------------|--------------|
| A2C59512545<br>A2C59512546 | Black<br>White | 8 – 16 V                   | 8 – 16 VDC   |
| A2C59512458<br>A2C59512459 | Black<br>White | 18 – 32 V                  | 18 – 32 VDC  |

## AMMETER

| Part Number                | Dial Color     | Dial Scale (outer / inner) | Sensor Input |
|----------------------------|----------------|----------------------------|--------------|
| A2C59512328<br>A2C59512330 | Black<br>White | - 60 / + 60 A              | 60 mV        |
| A2C59512329<br>A2C59512331 | Black<br>White | - 150 / + 150 A            | 60 mV        |

## RUDDER ANGLE

| Part Number                | Dial Color     | Dial Scale (outer / inner) | Sensor Input |
|----------------------------|----------------|----------------------------|--------------|
| A2C59514154<br>A2C59514230 | Black<br>White | - 40° / + 40°              | 3 – 180 Ω    |

## ENGINE TRIM

| Part Number                | Dial Color     | Dial Scale (outer / inner) | Sensor Input |
|----------------------------|----------------|----------------------------|--------------|
| A2C59514180<br>A2C59514244 | Black<br>White | UP – DOWN                  | 167 – 10 Ω   |

# SAFETY INFORMATION



- No smoking! No open fire or heat sources!

- The product was developed, manufactured and inspected according to the basic safety requirements of EC Guidelines and state-of-the-art technology.
- The instrument is designed for use in grounded vehicles and machines as well as in pleasure boats, including non-classified commercial shipping.
- Use our product only as intended. Use of the product for reasons other than its intended use may lead to personal injury, property damage or environmental damage. Before installation, check the vehicle documentation for vehicle type and any possible special features!
- Use the assembly plan to learn the location of the fuel/hydraulic/compressed air and electrical lines!
- Note possible modifications to the vehicle, which must be considered during installation!
- To prevent personal injury, property damage or environmental damage, basic knowledge of motor vehicle/shipbuilding electronics and mechanics is required.
- Make sure that the engine cannot start unintentionally during installation!
- Modifications or manipulations to veratron products can affect safety. Consequently, you may not modify or manipulate the product!
- When removing/installing seats, covers, etc., ensure that lines are not damaged and plug-in connections are not loosened!
- Note all data from other installed instruments with volatile electronic memories.

## SAFETY DURING INSTALLATION

- During installation, ensure that the product's components do not affect or limit vehicle functions. Avoid damaging these components!
- Only install undamaged parts in a vehicle!
- During installation, ensure that the product does not impair the field of vision and that it cannot impact the driver's or passenger's head!
- A specialized technician should install the product. If you install the product yourself, wear appropriate work clothing. Do not wear loose clothing, as it may get caught in moving parts. Protect long hair with a hair net.
- When working on the on-board electronics, do not wear metallic or conductive jewelry such as necklaces, bracelets, rings, etc.
- If work on a running engine is required, exercise extreme caution. Wear only appropriate work clothing as you are at risk of personal injury, resulting from being crushed or burned.
- Before beginning, disconnect the negative terminal on the battery, otherwise you risk a short circuit. If the vehicle is supplied by auxiliary batteries, you must also disconnect the negative terminals on these batteries! Short circuits can cause fires, battery explosions and damages to other electronic systems. Please note that when you disconnect the battery, all volatile electronic memories lose their input values and must be reprogrammed.
- If working on gasoline boat motors, let the motor compartment fan run before beginning work.
- Pay attention to how lines and cable harnesses are laid so that you do not drill or saw through them!
- Do not install the product in the mechanical and electrical airbag area!
- Do not drill holes or ports in load-bearing or stabilizing stays or tie bars!
- When working underneath the vehicle, secure it according to the specifications from the vehicle manufacturer.
- Drill small ports; enlarge and complete them, if necessary, using taper milling tools, saber saws, keyhole saws or files. Deburr edges. Follow the safety instructions of the tool manufacturer.

- Use only insulated tools, if work is necessary on live parts.
- Use only the multimeter or diode test lamps provided, to measure voltages and currents in the vehicle/machine or boat. Use of conventional test lamps can cause damage to control units or other electronic systems.
- The electrical indicator outputs and cables connected to them must be protected from direct contact and damage.

- The cables in use must have enough insulation and electric strength and the contact points must be safe from touch.
- Use appropriate measures to also protect the electrically conductive parts on the connected consumer from direct contact. Laying metallic, uninsulated cables and contacts is prohibited.

#### SAFETY AFTER INSTALLATION

- Connect the ground cable tightly to the negative terminal of the battery.
- Reenter/reprogram the volatile electronic memory values.
- Check all functions.
- Use only clean water to clean the components. Note the Ingress Protection (IP) ratings (IEC 60529).

#### ELECTRICAL CONNECTION

- Note cable cross-sectional area!
- Reducing the cable cross-sectional area leads to higher current density, which can cause the cable cross-sectional area in question to heat up!
- When installing electrical cables, use the provided cable ducts and harnesses; however, do not run cables parallel to ignition cables or to cables that lead to large electricity consumers.
- Fasten cables with cable ties or adhesive tape. Do not run cables over moving parts. Do not attach cables to the steering column!
- Ensure that cables are not subject to tensile, compressive or shearing forces.
- If cables are run through drill holes, protect them using rubber sleeves or the like.
- Use only one cable stripper to strip the cable. Adjust the stripper so that stranded wires are not damaged or separated.
- Use only a soft soldering process or commercially available crimp connector to solder new cable connections!
- Make crimp connections with cable crimping pliers only. Follow the safety instructions of the tool manufacturer.
- Insulate exposed stranded wires to prevent short circuits.
- Caution: Risk of short circuit if junctions are faulty or cables are damaged.
- Short circuits in the vehicle network can cause fires, battery explosions and damages to other electronic systems. Consequently, all power supply cable connections must be provided with weldable connectors and be sufficiently insulated.
- Ensure ground connections are sound.
- Faulty connections can cause short circuits. Only connect cables according to the electrical wiring diagram.
- If operating the instrument on power supply units, note that the power supply unit must be stabilized and it must comply with the following standard: DIN EN 61000, Parts 6-1 to 6-4.

# MECHANICAL INSTALLATION



**WARNING**

Before beginning, disconnect the negative terminal on the battery, otherwise you risk a short circuit.

If the vehicle is supplied by auxiliary batteries, you must also disconnect the negative terminals on these batteries! Short circuits can cause fires, battery explosions and damages to other electronic systems. Please note that when you disconnect the battery, all volatile electronic memories lose their input values and must be reprogrammed.

## BEFORE THE ASSEMBLY

1. Before beginning, turn off the ignition and remove the ignition key. If necessary, remove the main circuit switch.

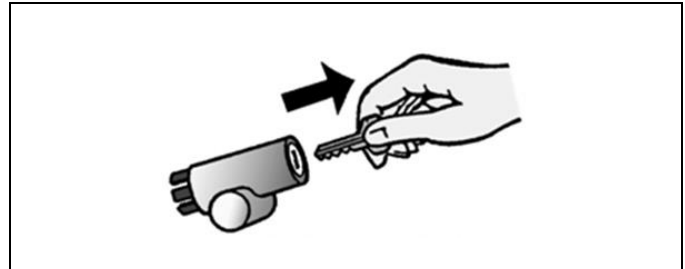

2. Disconnect the negative terminal on the battery. Make sure the battery cannot unintentionally restart.

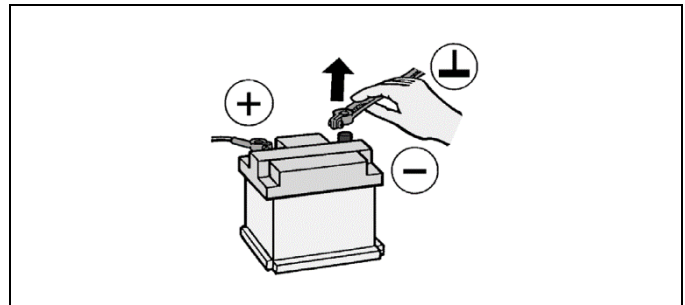

3. Place the device at least 500 mm away from any magnetic compass.

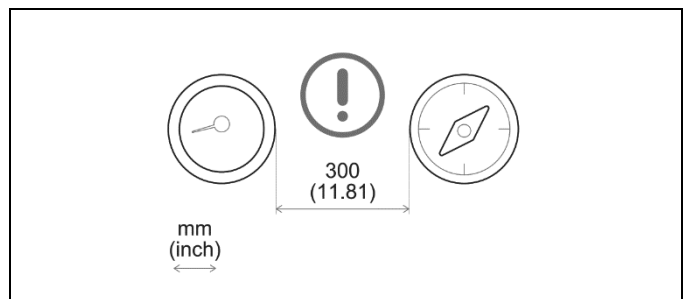



## INSTALLATION WITH SPINLOCK

Conventional assembly. (Instrument is put into the drill hole from the front).

The panel width may be within a range of 0.5 to 20 mm. The drill hole must have a diameter of 53 mm [B].

 **WARNING**

- Do not drill holes or ports in load-bearing or stabilizing stays or tie bars!
- Note the necessary clearance behind the drill hole or port at the installation location. Required mounting depth: 65 mm.
- Drill small ports; enlarge and complete them, if necessary, using taper milling tools, saber saws, keyhole saws or files. Deburr edges. Follow the safety instructions of the tool manufacturer.

1. Different bezels may be installed as alternatives to the supplied front ring. In this case, gently remove the bezel using a screwdriver [A] and install the new bezel on the instrument and press it on until it is flush with the instrument glass.

**Note:** the bezel cannot be used after removal since it can be damaged.

**IMPORTANT:** if installing a chrome bezel, make sure to configure the device **BEFORE** installing it, as the metallic particles contained in the chrome material might affect the NFC performance!

2. Create a circular hole in the panel considering the device dimensions. [B]
3. Remove the spinlock and insert the device from the front. [C]
4. Adjust the spinlock as shown in picture [D] according to the panel thickness
5. Carefully screw in the spinlock by hand at least two turns.
6. Insert the connector.

A

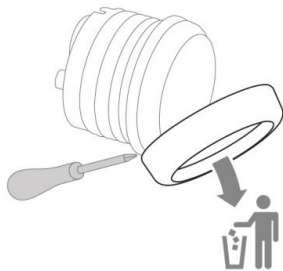

B

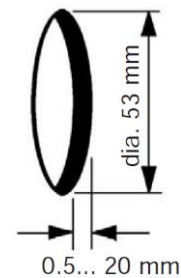

C

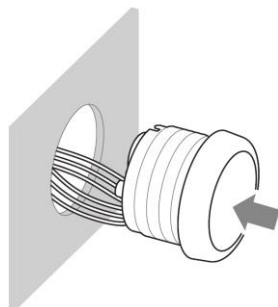

D

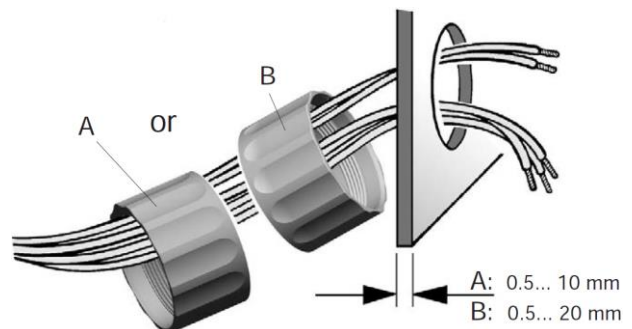

## FLUSH MOUNTING

The recommended panel thickness is 1.5 to 3 mm. The drill hole must have a diameter of 48.1 mm. [A]  
Ensure that the installation location is level and has no sharp edges.

 **WARNING**

- Do not drill holes or ports in load-bearing or stabilizing stays or tie bars!
- Note the necessary clearance behind the drill hole or port at the installation location. Required mounting depth: 65 mm.
- Drill small ports; enlarge and complete them, if necessary, using taper milling tools, saber saws, keyhole saws or files. Deburr edges. Follow the safety instructions of the tool manufacturer.

1. Create a circular hole in the panel considering the device dimensions. [A]
2. Remove the spinlock.
3. Gently remove the bezel using a screwdriver. [B]  
**Note:** the bezel cannot be used after removal since damaged.
4. Place the flush mount seal A2C53215640 (not included) on the instrument glass.
5. Put the instrument into the drill hole from the back [C].
6. Adjust the instrument so that the gauge is level and fasten it to the stud bolts on the rear side of the panel, using the flush mount fixing bracket A2C59510864 (not included) [D].
7. Insert the connector.

A

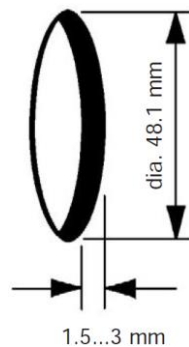

B

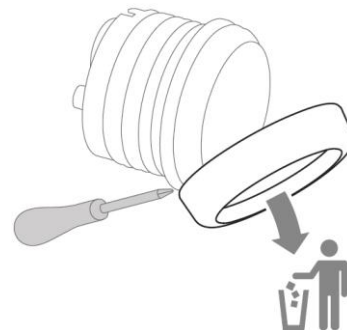

C

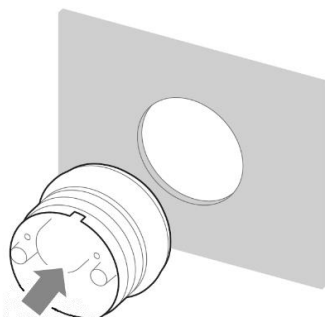

D

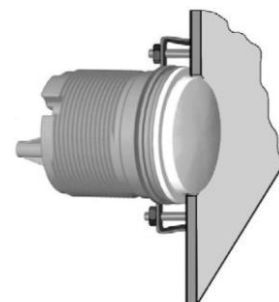

## INSTALLATION WITH BRACKETS

Konventionelle Montage. (Gerät wird von vorn in die Bohrung gesteckt).

Die Panelstärke kann im Bereich von 0,5 bis 20 mm liegen. Die Bohrung muss einen Durchmesser von 53 mm haben **[B]**.

 **WARNING**

- Do not drill holes or ports in load-bearing or stabilizing stays or tie bars!
- Note the necessary clearance behind the drill hole or port at the installation location. Required mounting depth: 65 mm.
- Drill small ports; enlarge and complete them, if necessary, using taper milling tools, saber saws, keyhole saws or files. Deburr edges. Follow the safety instructions of the tool manufacturer.

1. Create a circular hole in the panel considering the device dimensions.

2. Remove the spinlock and insert the device from the front.

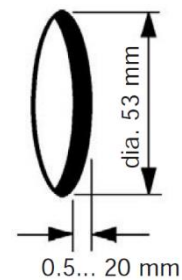

3. Screw the stud bolts into the provided drill holes in the enclosure.

Max. stud bolt torque is 1.5 Nm.

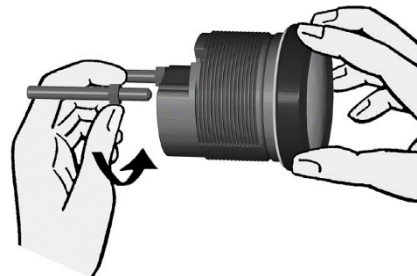

4. Place the bracket on the stud bolt and hand-tighten the knurled nut.

Make sure the seal lays flat between the panel and the front ring.

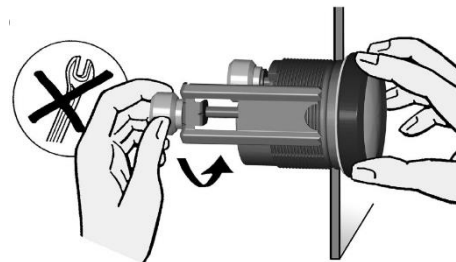

# ELECTRICAL INSTALLATION



- Refer to the safety rules described in the electrical connections section of the safety information chapter of this document!

Depending on the configuration, insert the cable into the 8-pin contact enclosure according to the following pin assignment.

The contacts must audibly lock into place.

Now insert the plug into the gauge.

Note the inverse polarity protection nose in the process.

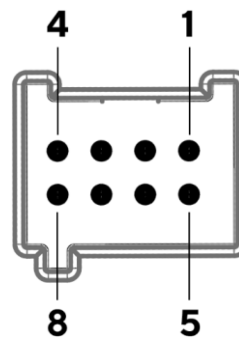

| Pin No. | Wire color     | Description                      |
|---------|----------------|----------------------------------|
| 1       | Red            | KL. 15 – Ignition plus           |
| 2       | Black          | KL. 31 – Ground                  |
| 3       | Black / Blue   | Sensor ground *                  |
| 4       | Brown          | KL. 30 – Battery Power 12 / 24 V |
| 5       | Green          | Sensor signal *                  |
| 6       | Blue / Red     | KL. 58 – Illumination            |
| 7       | Yellow / Black | Warning LED ground               |
| 8       | Yellow / Red   | Warning LED plus                 |

\* not connected on voltmeter instruments

CONNECTION DIAGRAM FOR:  
 TEMPERATURE / PRESSURE / RUDDER / TRIM / LEVEL GAUGES (RESISTIVE)

Designations in the wiring diagrams:

30 – Term. 30 – steady-state plus 12 V  
 15 – Term. 15 – connected (ignition) plus

58 – Term. 58 - lighting  
 31 – Term. 31 - ground

F1 – Fuse 5A quick-response  
 L1 – External warning lamp (max. 1 A)

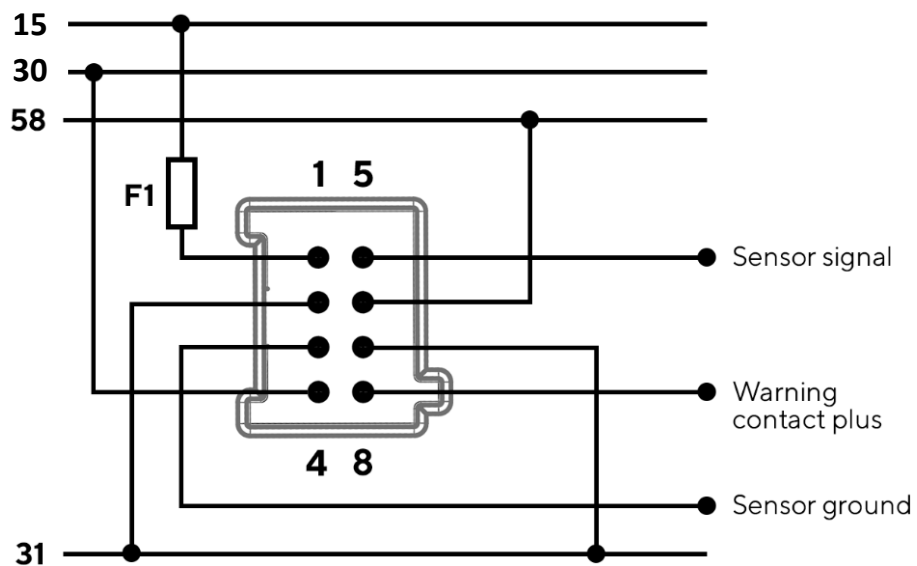
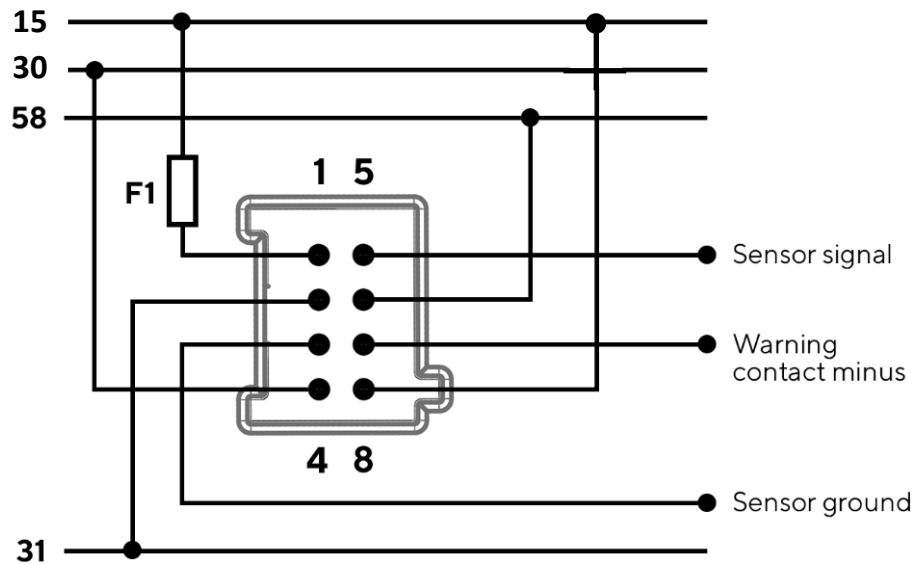

CONNECTION DIAGRAM FOR: LEVEL GAUGES (CAPACITIVE SENSORS)

Connections to sensors  
**N02-240 /-402 /-404 /-406**

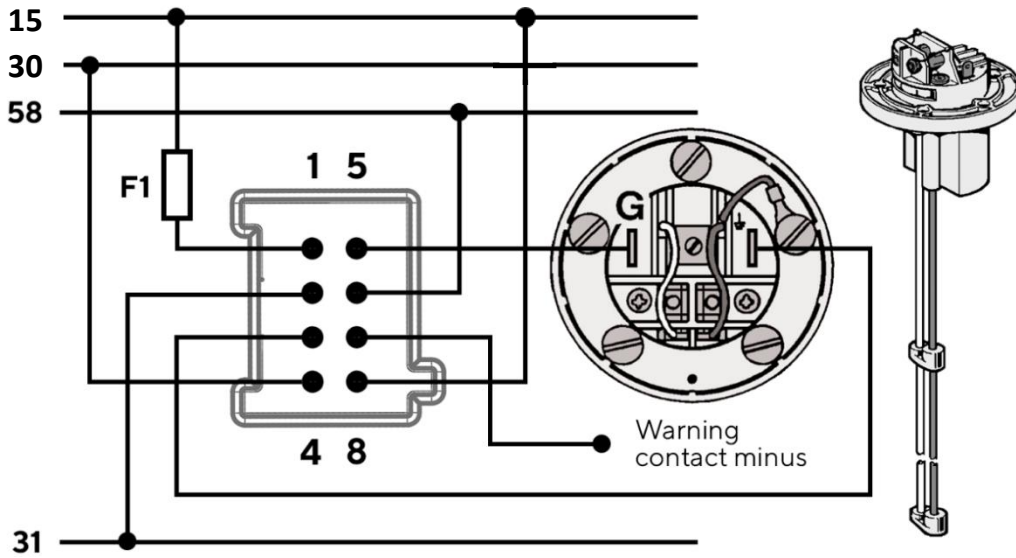

Connection to sensors  
**N02-240 /-802 /-902 /-904 /-906**

|   |       |   |        |
|---|-------|---|--------|
| 1 | Green | 2 | Yellow |
| 3 | White | 4 | Brown  |

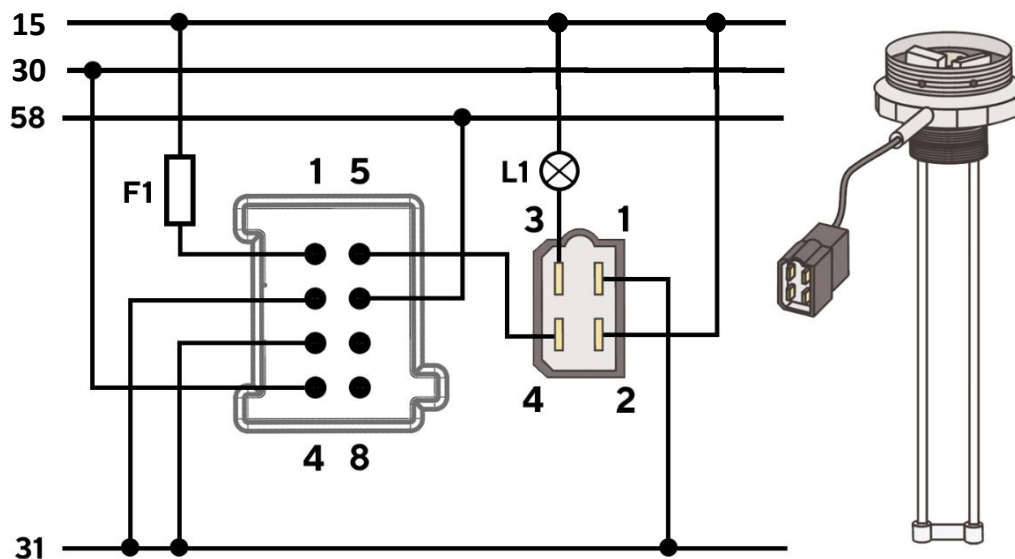

## CONNECTION DIAGRAM FOR: EXHAUST TEMPERATURE GAUGES (PYROMETER SENSOR)



WARNING

- Do not shorten the measuring lead!

Connection to pyrometer sensor  
N03-320-264 via 6 m extension  
cable N03-320-268.

Extension Cable

|   |        |        |
|---|--------|--------|
| A | Red    | GND    |
| C | Yellow | Signal |

Pyrometer sensor

|   |       |        |
|---|-------|--------|
| B | White | GND    |
| D | Blue  | Signal |

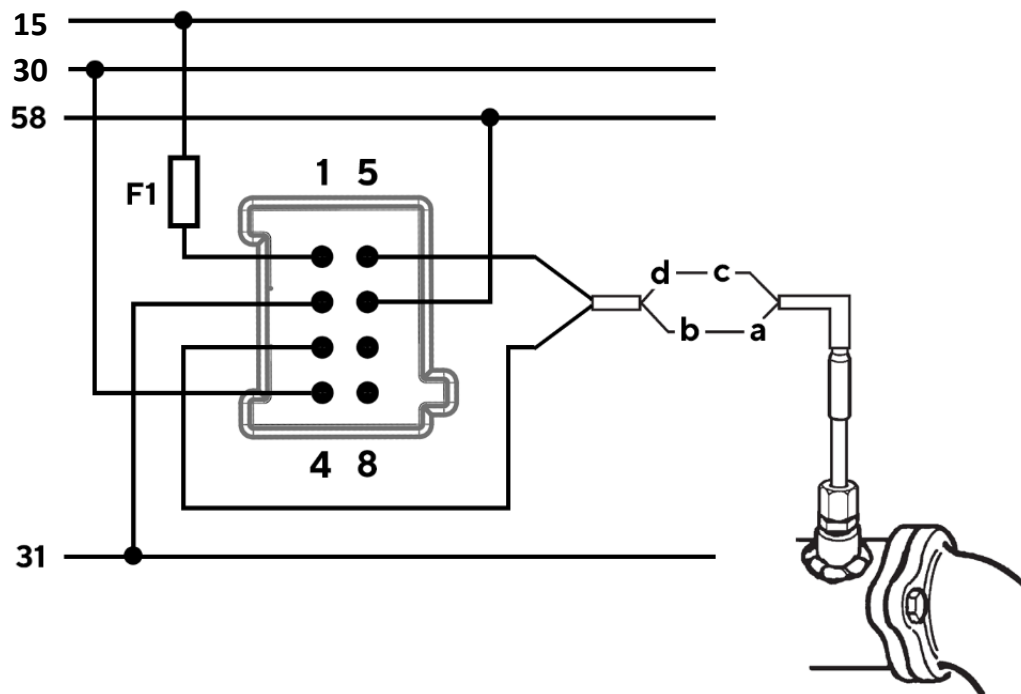

CONNECTION DIAGRAMM FOR: VOLTMETER GAUGES

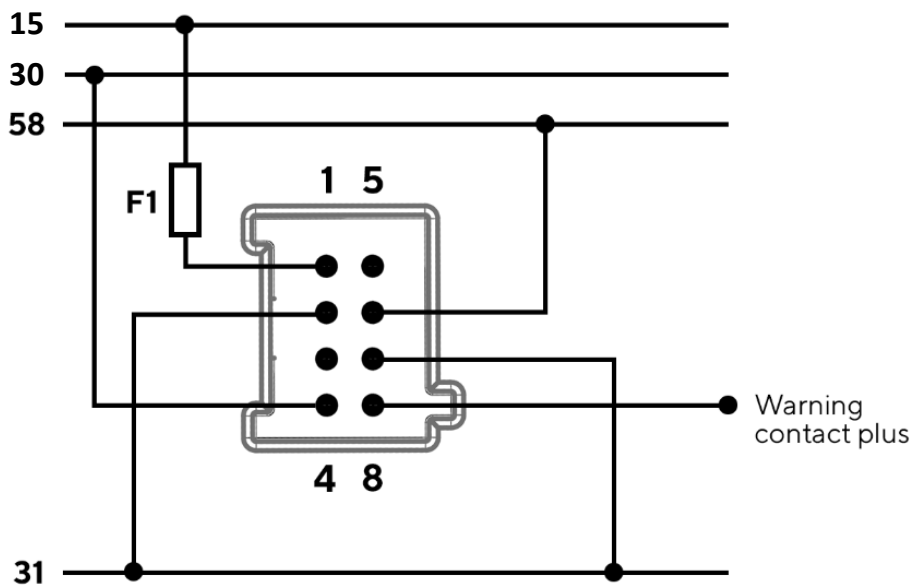
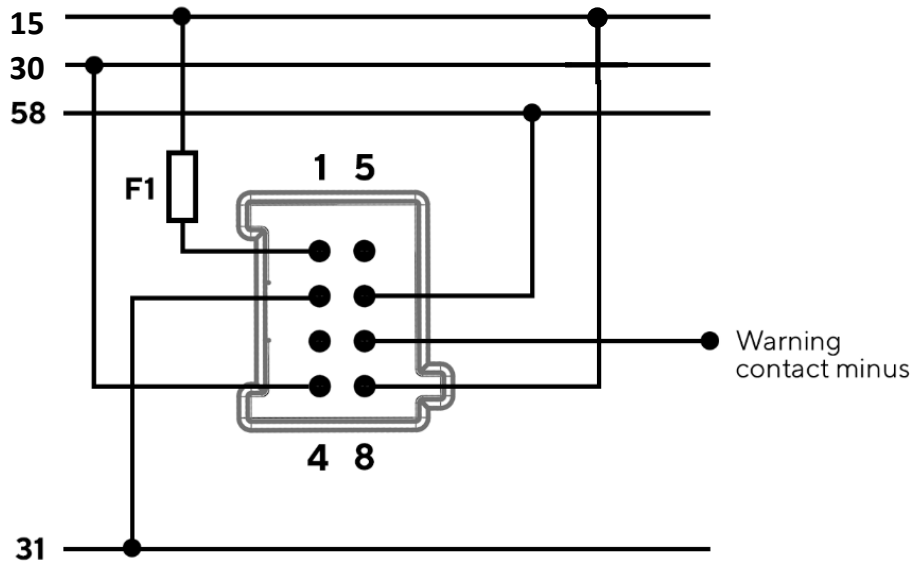



## CONNECTION DIAGRAM FOR: AMMETER GAUGES

Connection to the ammeter shunt

A2C59514043 (60 A) and A2C59514047 (150 A) via 10 m extension cable A2C59512679.

Designations in the wiring diagrams:

30 – Term. 30 – steady-state plus 12 V  
 15 – Term. 15 – connected (ignition) plus  
 58 – Term. 58 – lighting

31 – Term. 31 - ground  
 F1 – Fuse 5A quick-response  
 A1 – Alternator

B1 – Battery  
 S1 – Starter

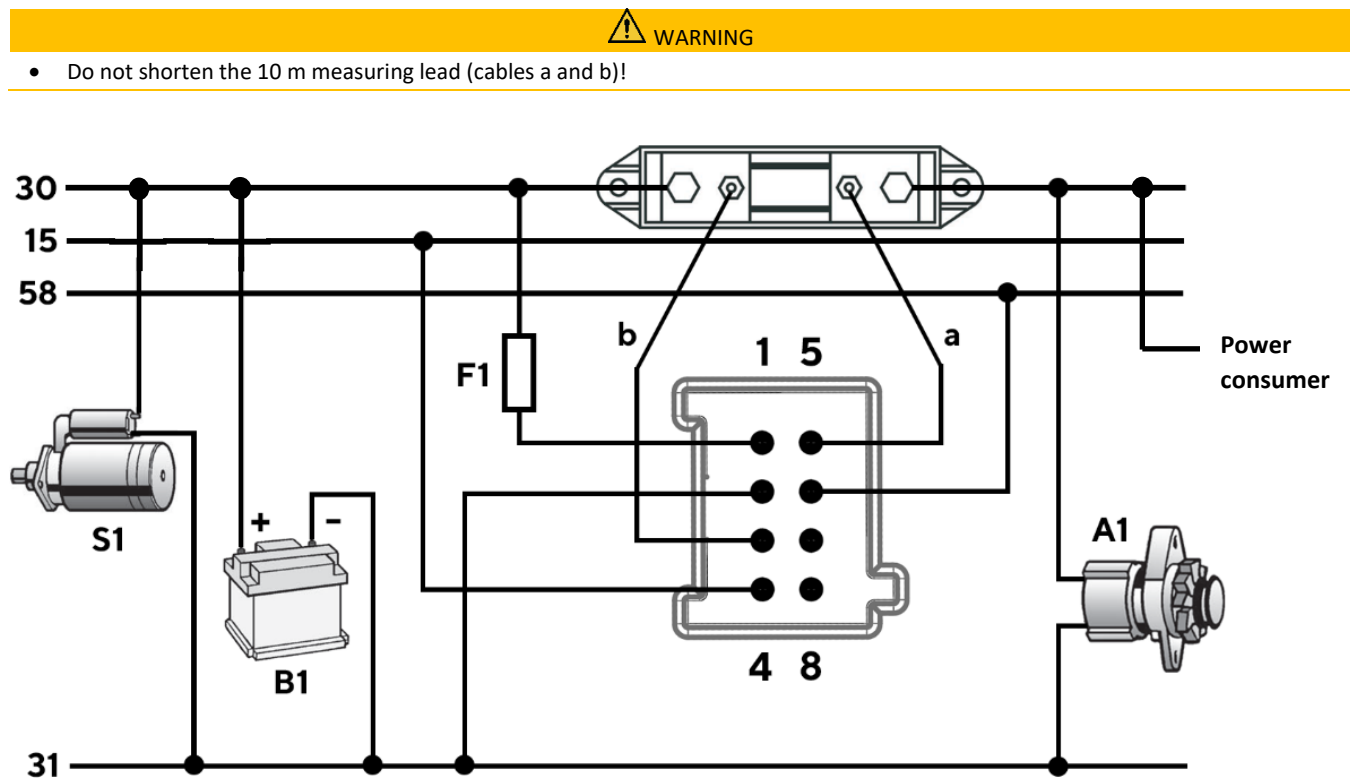

The starter current should not go through the shunt.

**! WARNING**

Pinout is NOT the same as for other gauges!



WARNING

- Do not reduce the existing cable cross section!

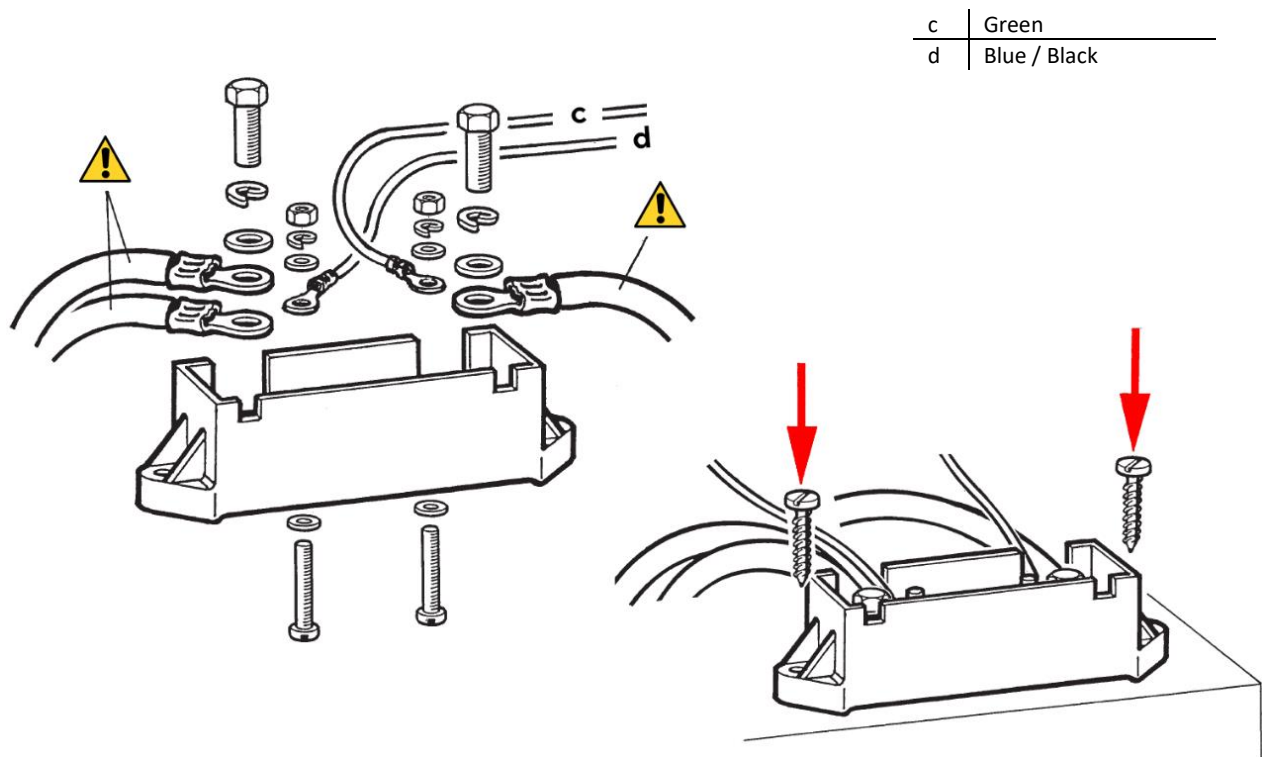

#### General Terminal Diagram:

In special cases, show the ship's electrical diagram to your boatyard or to a branch or agent and ask for advice on how to connect the sensors.

# TECHNICAL DATA

## DATASHEET

|                              |   |
|------------------------------|---|
| <b>Nominal Voltage</b>       | 12 V / 24 V   |
| <b>Operating Voltage</b>     | 10 – 32 V with overvoltage and reverse polarity protection  |
| <b>Current consumption</b>   | < 140 mA with warning LED   |
| <b>Protection class</b>      | IP 67 front side, IP 52 rear side acc. IEC60529   |
| <b>Lens</b>                  | PMMA double lens  |
| <b>Housing</b>               | ∅52 mm – Polycarbonate (PC)   |
| <b>Installation depth</b>    | 50 mm   |
| <b>Bezels</b>                | PC (black, white) or ABS (chrome) – several color and shapes  |
| <b>Dial</b>                  | Backlit, different colors (black, white)  |
| <b>Pointer</b>               | Backlit, white on black dials; red on white dials<br>90° and 270° deflection angle                  |
| <b>Illumination</b>          | Dial: LED amber (605 nm) Pointer: LED red (632 nm)  |
| <b>Warning LED</b>           | Red (632 nm)  |
| <b>Operating temperature</b> | -30°C to +80°C<br>with chrome bezel -30°C to +70°C  |
| <b>Storage temperature</b>   | -30°C to +80°C<br>with chrome bezel -30°C to +70°C  |
| <b>Flammability</b>          | flame retardant acc. UL94-V0  |
| <b>Connector</b>             | Tyco / Hirschmann MQS connector 8 pins  |
| <b>Mounting</b>              | Spinlock Nut – locking height 0.5 – 20 mm<br>Optional Studs and Brackets – locking height 2 – 15 mm |
| <b>Certifications</b>        | CE, Reach, RoHS   |

# ACCESSORIES

| Description                   | Part Number   |
|-------------------------------|---------------|
| Adapter cable 8-poles         | A2C59512947   |
| 10 m Ammeter harness          | A2C59512679   |
| Spinlock Nut 52 mm            | A2C5205947101 |
| Flush mount mounting kit      | A2C59510864   |
| Flush mount seal              | A2C53215640   |
| Bracket assembly mounting kit | A2C59510854   |
| Connector set 8 pins          | A2C59510850   |
| Blind plug for 52 mm          | A2C5312164501 |
| Make-Point switch             | A2C59510886   |
| Bezel – Round Black           | A2C5318602701 |
| Bezel – Round White           | A2C5318602801 |
| Bezel – Round Chrome          | A2C5318602901 |
| Bezel – Triangular Black      | A2C5318602401 |
| Bezel – Triangular White      | A2C5318602501 |
| Bezel – Triangular Chrome     | A2C5318602601 |
| Bezel – Flat Black            | A2C5318604001 |
| Bezel – Flat White            | A2C5318602201 |
| Bezel – Flat Chrome           | A2C5318602301 |

Visit <http://www.veratron.com> for the complete list of accessories.



**veratron AG**  
Industriestrasse 18  
9464 Rüthi, Switzerland

T +41 71 7679 111  
info@veratron.com  
veratron.com

---

Any distribution, translation or reproduction, partial or total, of the document is strictly prohibited unless with prior authorization in writing from veratron AG, except for the following actions:

- Printing the document in its original format, totally or partially.
- Copying contents without any modifications and stating veratron AG as copyright owner.

Veratron AG reserves the right to make modifications or improvements to the relative documentation without notice.

Requests for authorization, additional copies of this manual or technical information on the latter, must be addressed to veratron AG.