

12V c.c. - d.c.

011-A40-22

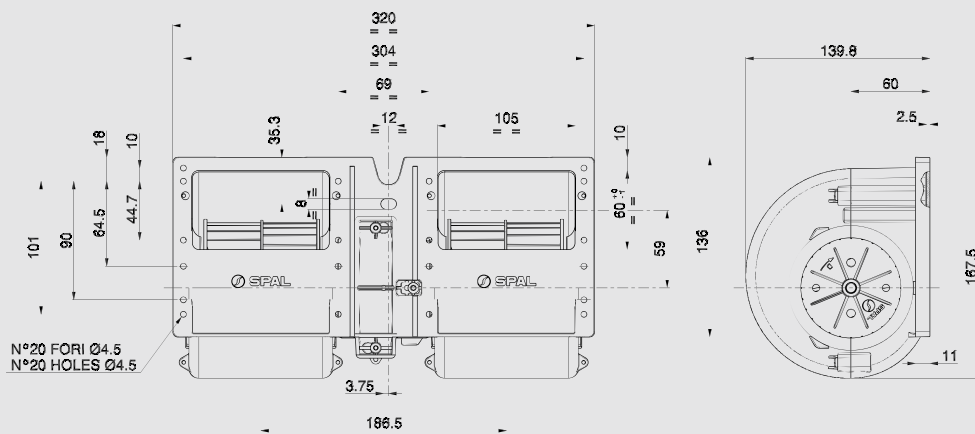

Suggested mounting torque: 3 +1/- 0 Nm with screw M4
Weight 2,1 Kg. approx.

Coppia di serraggio consigliata: 3 +1/- 0 Nm con vite M4
Peso 2,1 Kg. circa

011

PERFORMANCE CHART
SCHEDA PRESTAZIONI

Static pressure Pressione statica mm H ₂ O	Airflow Portata m ³ /h	Current input Corrente assorbita A	Airflow Portata CFM	Static pressure Pressione statica in H ₂ O
0	900	21,7	531	0
10	830	20,6	490	0,4
20	750	19,7	443	0,8
30	640	18,3	378	1,2
40	560	15,8	330	1,6
50	420	14,4	248	2,0
60	160	10,6	94	2,4
70	0	10,1	0	2,8

Test voltage 13 V d.c. - Tensione di prova 13 V c.c.



PRODUCT FEATURES
CARATTERISTICHE PRODOTTO

Long life Lunga durata	✓
3 or 4 speed resistor Resistenza a 3 o 4 velocità	✓
VLL version* Versione VLL*	✓

✓ = Standard feature
Caratteristica standard

✓ = Available upon request
Disponibile su richiesta

* for OEM applications only
* per applicazioni OEM