

Absolute-pressure sensors

Media-resistant, micromechanical

Input quantity: P

Output quantity: U

- Available as separate component or fitted in an extremely robust housing.
- EMC protection up to 100 Vm⁻¹
- With temperature compensation
- Ratiometric output signal
- All sensors and sensor cells are resistant to fuels (including diesel) and oils such as engine oil.



Application

Monolithically integrated silicon pressure sensors are extremely precise measuring elements for determining absolute pressure. They are particularly suitable for use under harsh ambient conditions, such as the measurement of the absolute intake-manifold pressure in internal-combustion engines.

Design and operation

The sensor contains a silicon chip with etched pressure diaphragm. A change in pressure causes elongation of the diaphragm and this is recorded by an evaluation circuit on the basis of changes in resistance. The circuit is integrated on the silicon chip together with electronic calibration elements. When manufacturing the silicon chip, a silicon wafer containing a number of sensor elements is attached to a glass plate. Once sawn into individual chips, each chip is soldered onto a metal base with pressure connection. The pressure is routed via the connection and the base to the back of the pressure diaphragm. A reference vacuum permitting measurement of the absolute pressure and at the same time protecting the front of the pressure diaphragm is enclosed beneath the cap, which is welded to the base. The programming logic on the chip performs calibration. The calibration parameters are permanently stored by means of thyristors (zener zapping) and etched conductive paths. The calibrated and tested sensors are fitted in a special housing for attachment to the intake manifold (refer to product range).

Signal evaluation

The pressure sensor supplies an analog output signal which has a ratiometric relationship with the supply voltage. It is

advisable to fit the input stage of the downstream electronics with an RC low-pass filter (e.g. $t = 2 \text{ ms}$) to suppress any interference due to harmonics. In the version with integrated temperature sensor, this consists of an NTC thermistor (to be used in conjunction with a series resistor) for measurement of the ambient temperature.

Installation instructions

On installation, the pressure connection should face downwards to stop condensate accumulating in the pressure cell.

Version

Sensors with housing:
This version features a sturdy housing. On the version with temperature sensor, the sensor is located in the housing.

Sensors without housing:
Enclosure similar to TO, pressure is supplied through a central pressure connection. The solder-pin assignment is as follows:
Pin 6 Output voltage UA,
Pin 7 Ground,
Pin 8 +5 V.

Note

1 connector housing, 3 contact pins and 3 individual seals are required for a 3-pin connector. 1 connector housing, 4 contact pins and 4 individual seals are required for a 4-pin connector.

Robert Bosch GmbH
Automotive Aftermarket
Postfach 410960
76225 Karlsruhe
Germany

www.bosch-sensoren.de



BOSCH
Invented for life

BOSCH

Invented for life

Part number

0 261 230 112

Technical data

Parameter		min	typ	max
Features				Integrated
temperature sensor				
Pressure range ($p_1...p_2$)	kPa	50		1000
Supply voltage U_V	V	4,75	5	5,25
Current input I_V at $U_V = 5$ V	mA	6	9	12,5
Load current I_L at output	mA	-1		0,5
Lower limit at $U_V = 5$ V	V	0,25	0,3	0,35
Upper limit at $U_V = 5$ V	V	4,75	4,8	4,85
Output resistance to ground, U_V open	k Ω	2,4	4,7	8,2
Output resistance to U_V , ground open	k Ω	3,4	5,3	8,2
Response time $\tau_{10/90}$	ms			1
Operating temperature	$^{\circ}\text{C}$	-40		+125

Limit data

Supply voltage U_V	V			16
Operating temperature	$^{\circ}\text{C}$	-40		+130

Recommendation for signal evaluation

Load resistance to $U_H = 5.5...16$ V	k Ω		680	
---------------------------------------	------------	--	-----	--

Temperature sensor

Measuring range	$^{\circ}\text{C}$	-40		+125
Measurement current ¹⁾	mA			1 ¹⁾
Rated resistance at +20 $^{\circ}\text{C}$	k Ω		2,5 \pm 6 %	
Temperature/time constant τ_{63^2}	s			45

Accessories are not included in the scope of delivery of the sensor and are therefore to be ordered separately as required.

Dimensional drawing

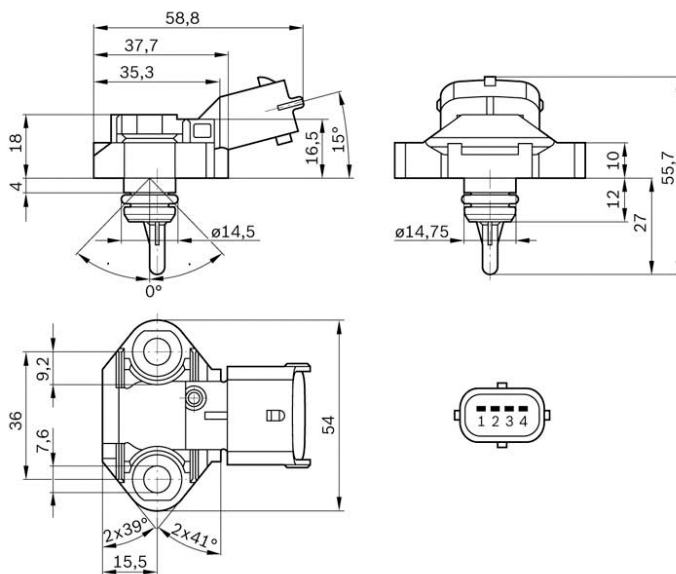

- Pin 1 Ground
- Pin 2 NTC thermistor
- Pin 3 +5 V
- Pin 4 Output signal

Characteristic curve

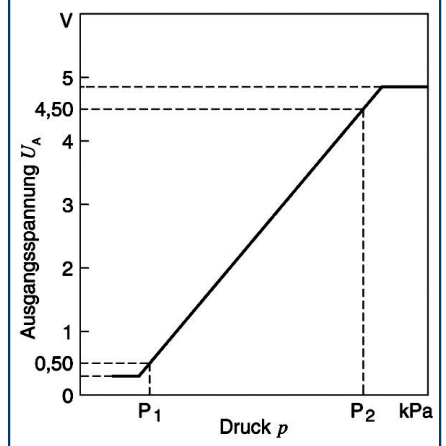



Characteristic-curve tolerance

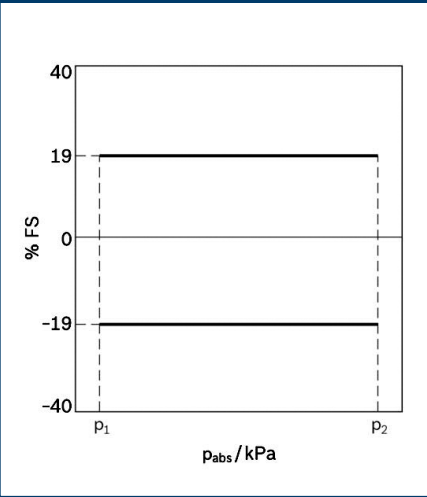

Tolerance extension factor

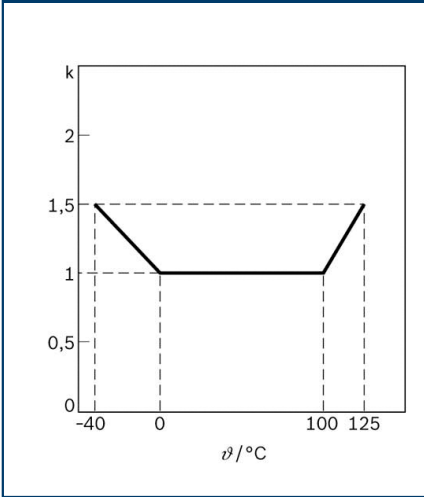

Characteristic curve for temperature sensor

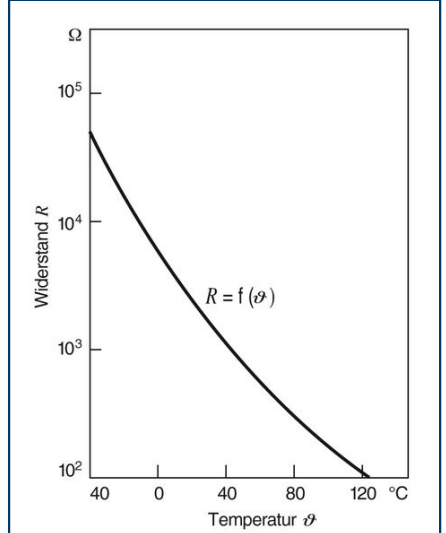

Applies to products with integrated temperature sensor.

Block diagram

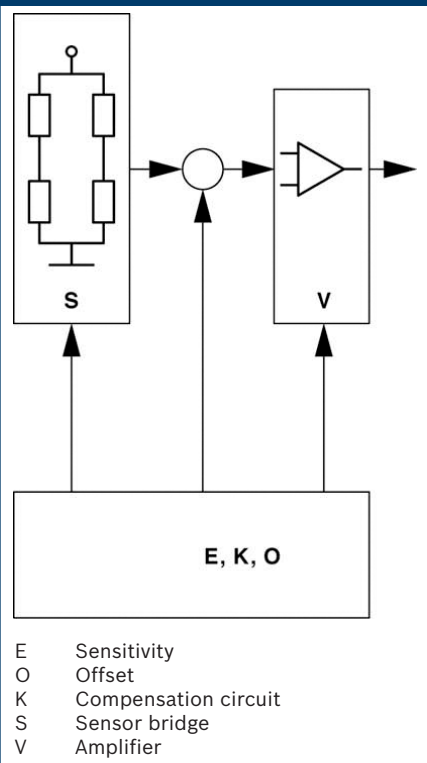

Pressure sensor in housing

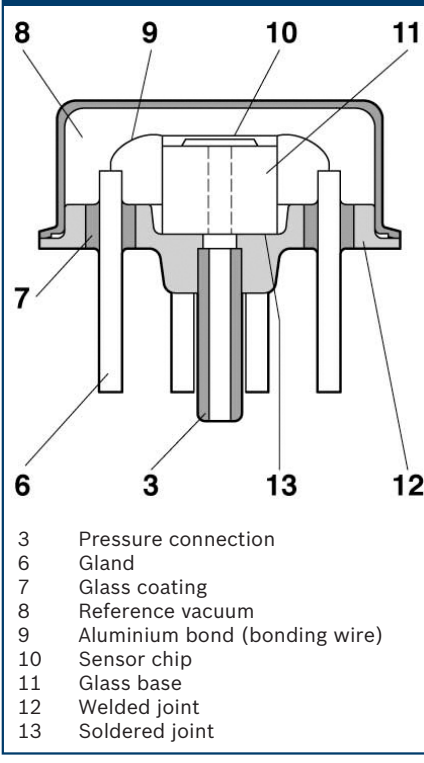

Section through installed pressure sensor

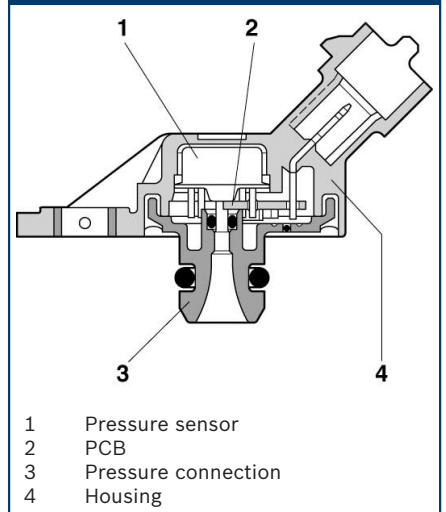

BOSCH

Invented for life

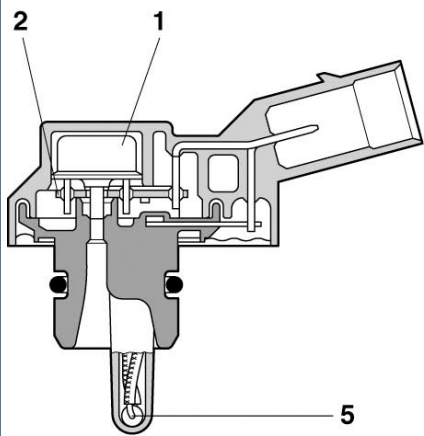
Pressure sensor installed

Version with temperature sensor

- 1 Pressure sensor
- 2 PCB
- 5 Temperature sensor

Accessories
Part number

Connector housing	4-pin	1 928 403 736
Contact pins	For \varnothing 0.5...1.0 mm ² ; Contents: 100 x	1 928 498 056
Contact pins	For \varnothing 1.5...2.5 mm ² ; Contents: 100 x	1 928 498 057
Single-wire seal	For \varnothing 0.5...1.0 mm ² ; Contents: 10 x	1 928 300 599
Single-wire seal	For \varnothing 1.5...2.5 mm ² ; Contents: 10 x	1 928 300 600
Dummy plug		1 928 300 601

Accessories are not included in the scope of delivery of the sensor and are therefore to be ordered separately as required.