

REV	ECN	DATE	BY	CHANGE OR ADDITION
NC	1203	6/20/2014	LUND	INITIAL RELEASE

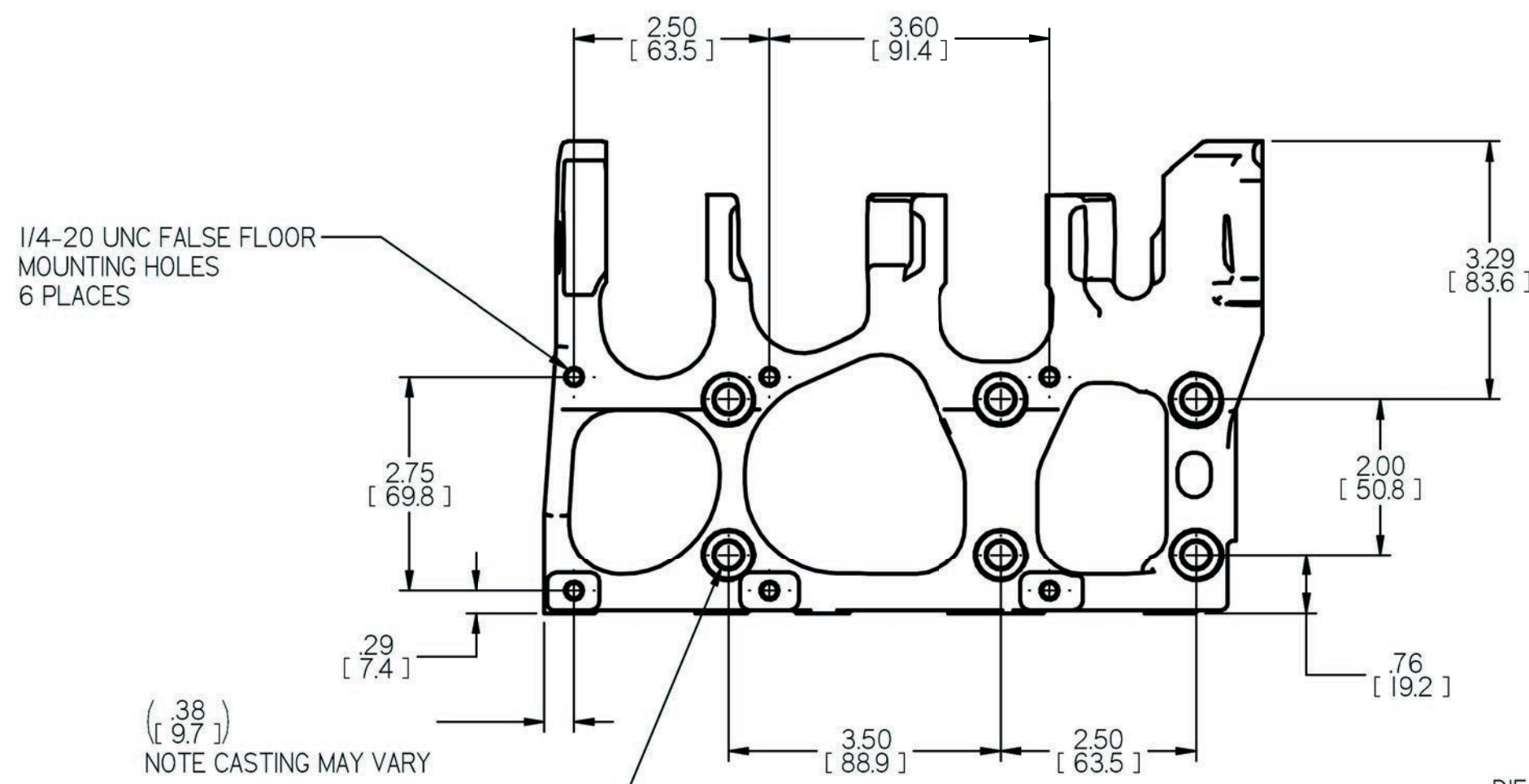

THRU HOLES FOR CUSTOMER SUPPLIED HIGH STRENGTH 5/16" OR 8MM SOCKET HEAD BOLTS .62/.58 [15.7/14.7] GRIP LENGTH OF FRAME 6 PLACES

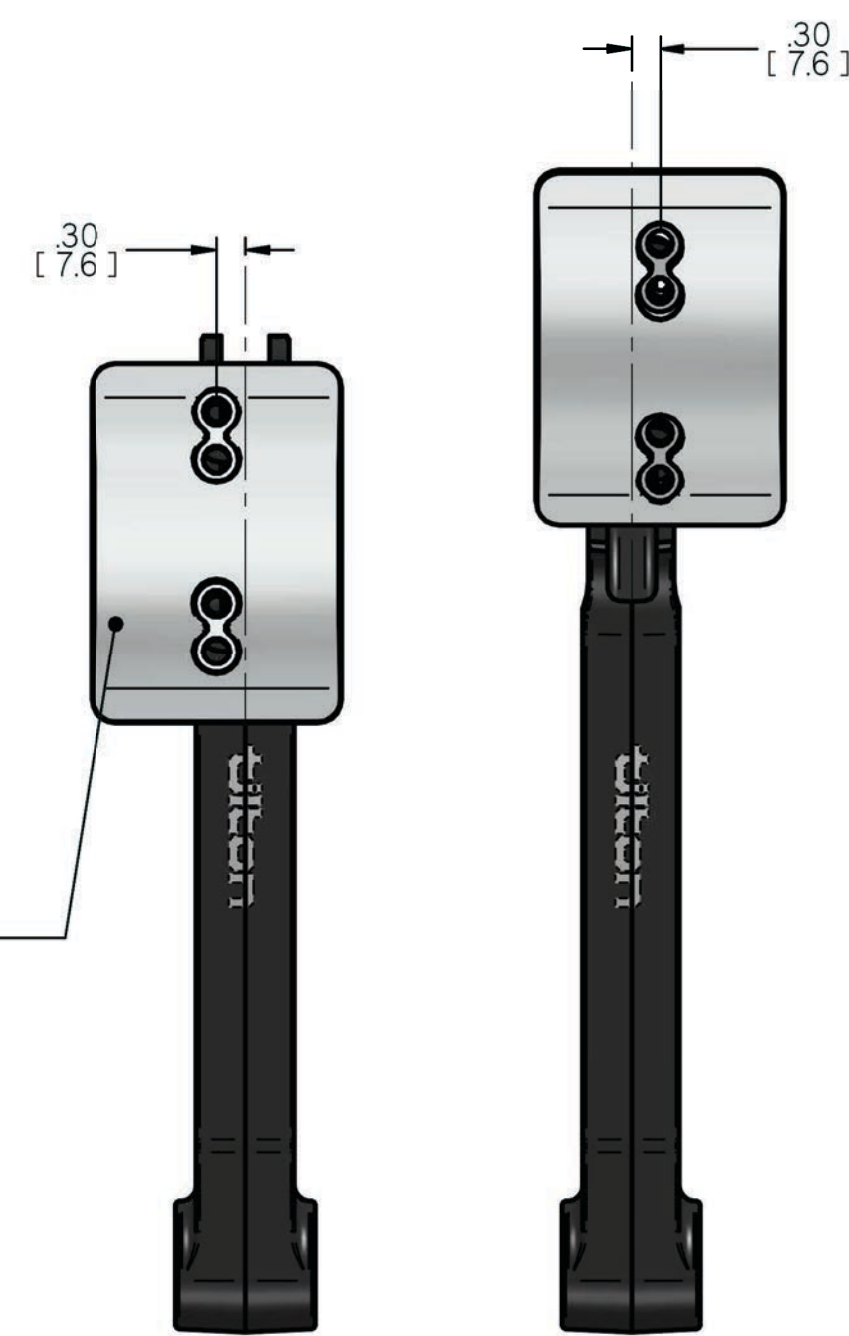

DIE-CUT ANTI-SLIP TAPE SUPPLIED WITH KIT BUT NOT INSTALLED, GIVING CHOICE OF SMOOTH OR ROUGH PAD SURFACES.

PEDAL RATIO ADJUSTABLE FROM 5.4:1 UP TO 6.9:1 DEPENDING ON PAD POSITION

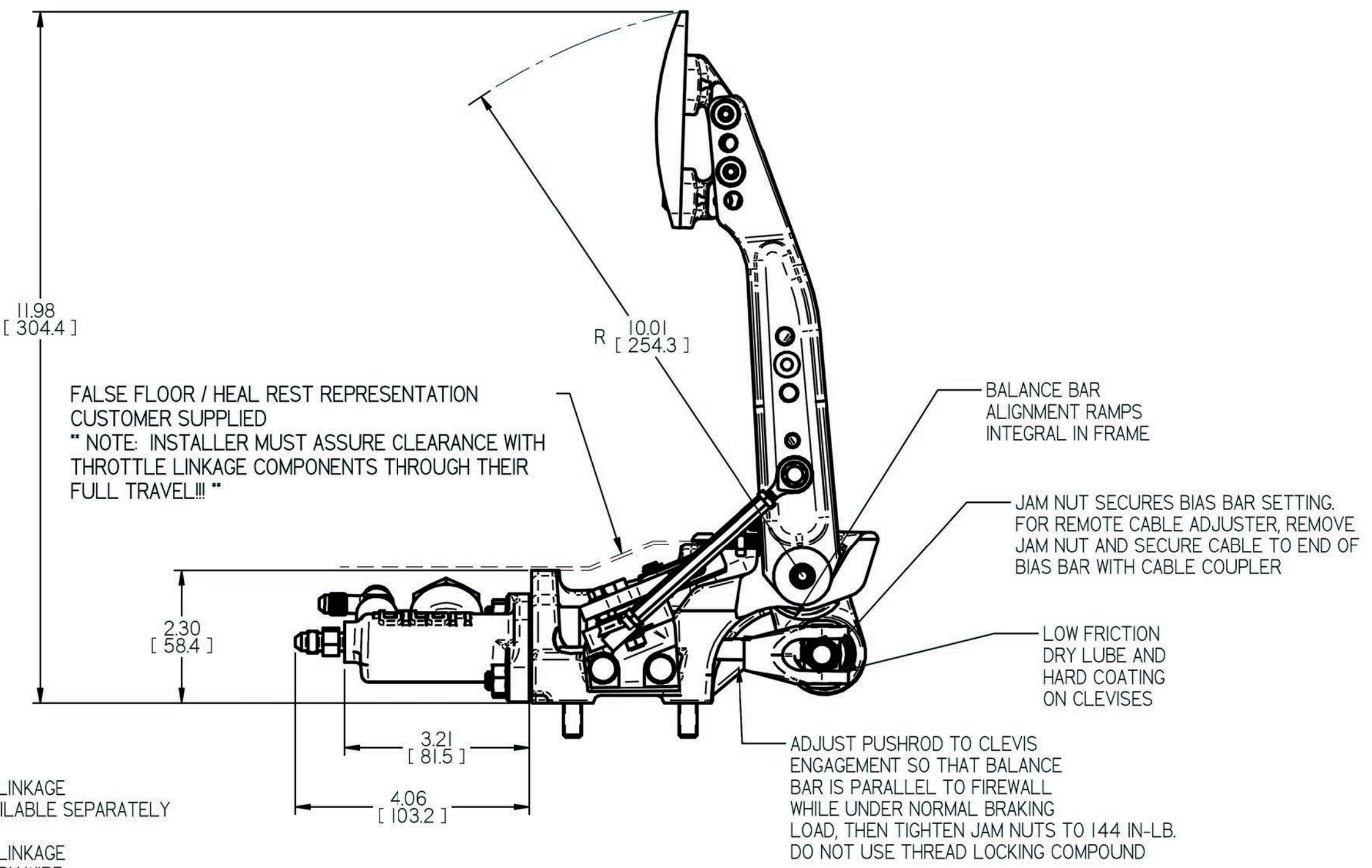
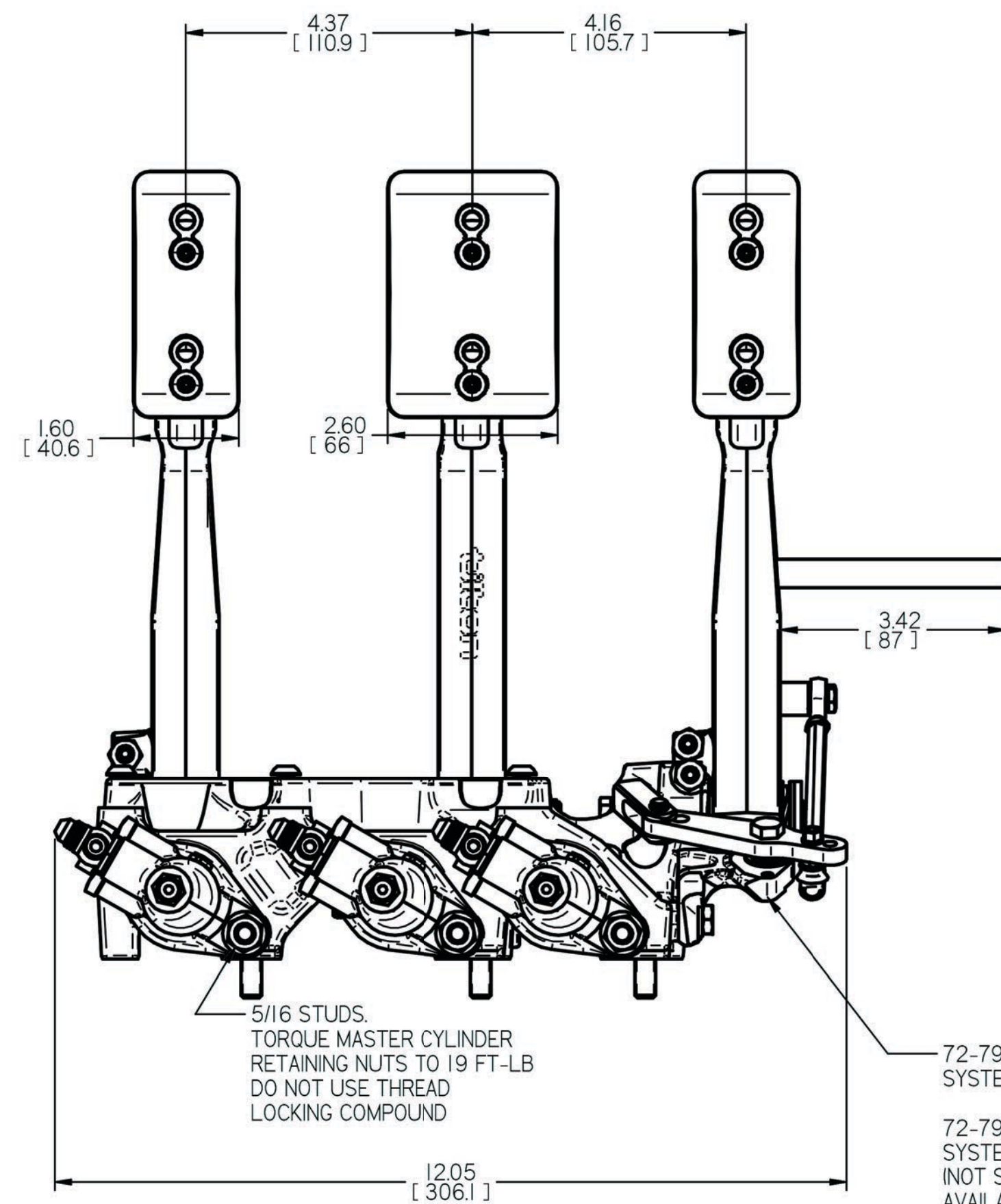
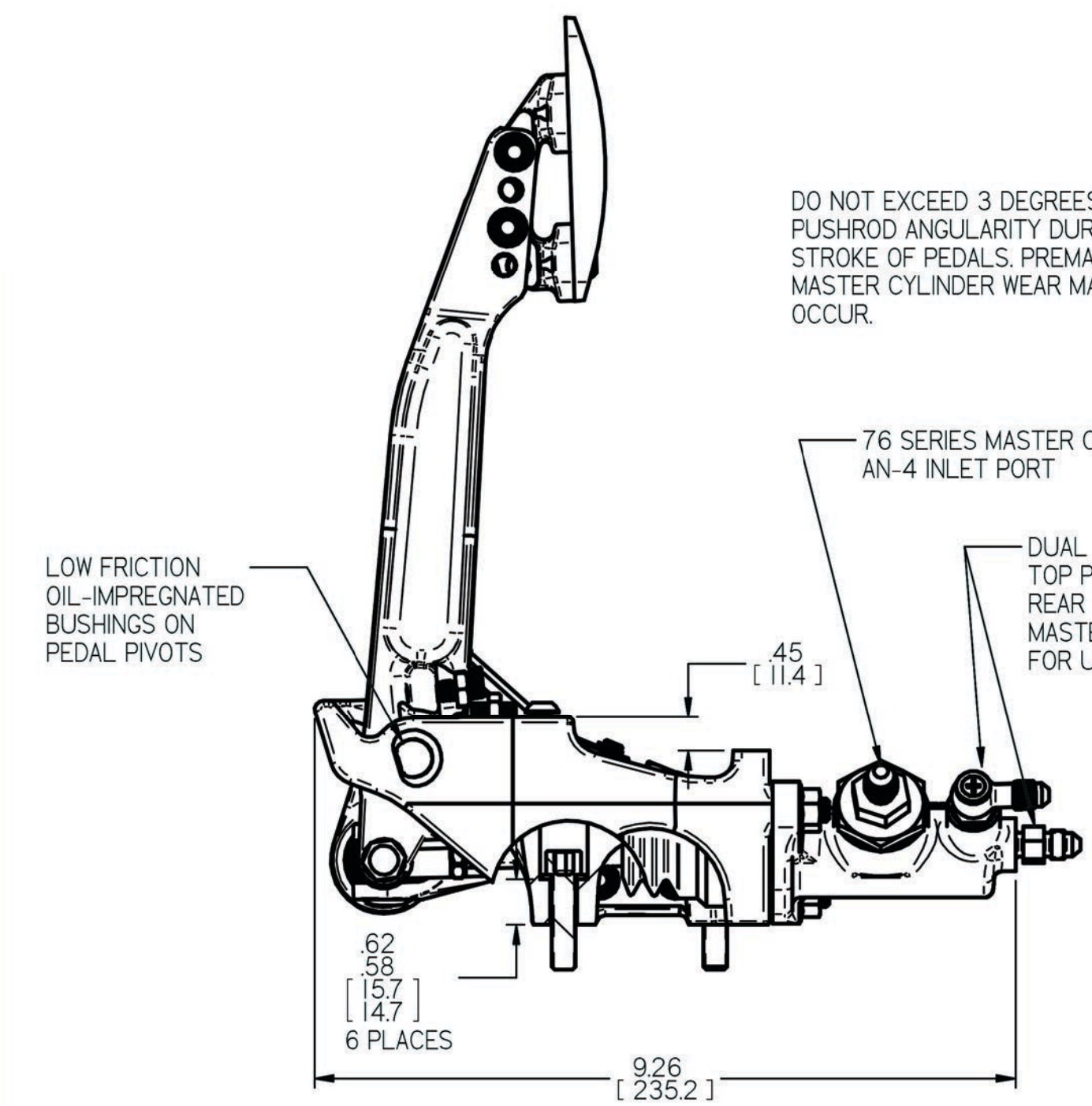
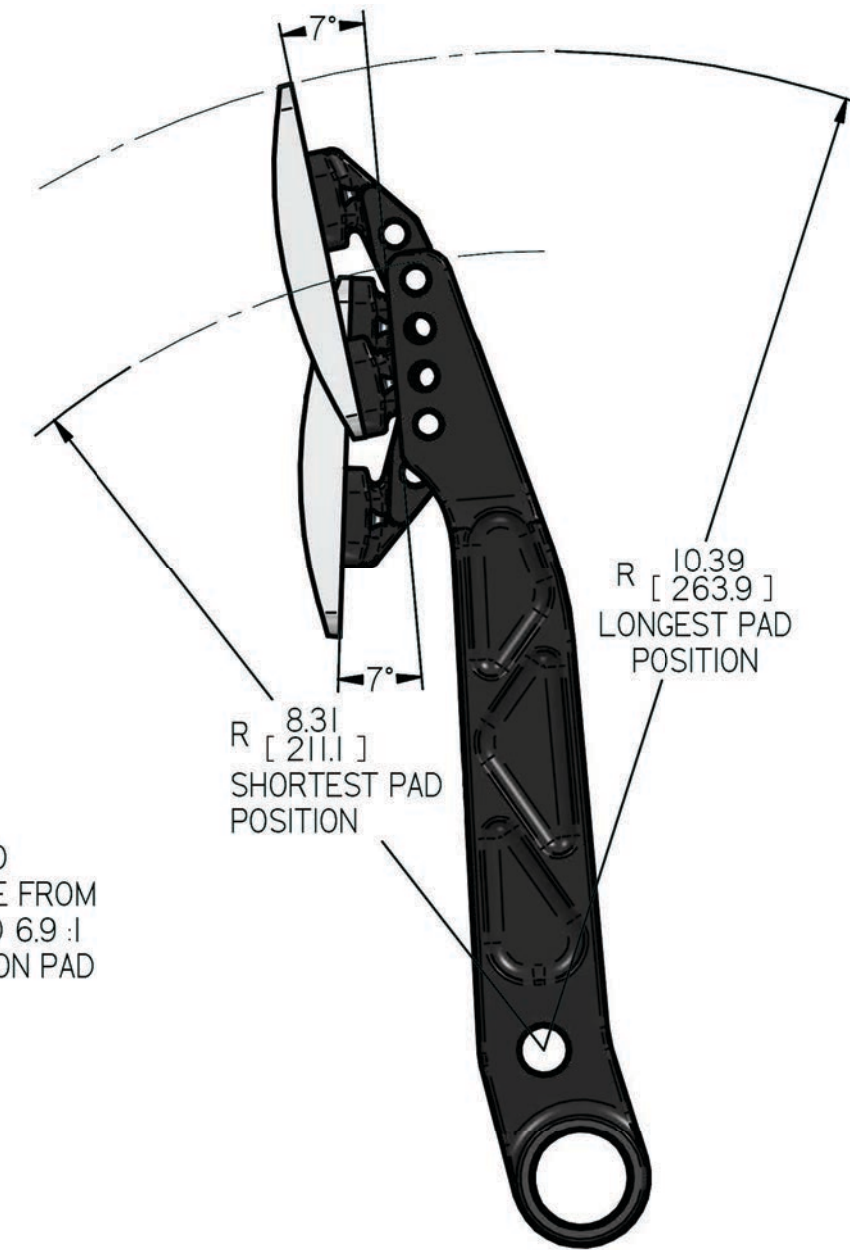

PEDAL ASSEMBLY IS COMPATIBLE WITH TILTON ENGINEERING 76 SERIES MASTER CYLINDERS SOLD SEPARATELY

76 SERIES MASTER CYLINDERS SHOWN HERE ARE FOR ILLUSTRATION PURPOSES ONLY AND ARE NOT INCLUDED WITH PEDAL ASSEMBLY

- NOTES:
1. DIMENSIONS AND TOLERANCES PER ASME Y14.5 - 2009
  2. UNLESS OTHERWISE SPECIFIED, ALL DIMENSIONS ARE IN INCHES.
  3. DIMENSIONS ARE NOMINAL.

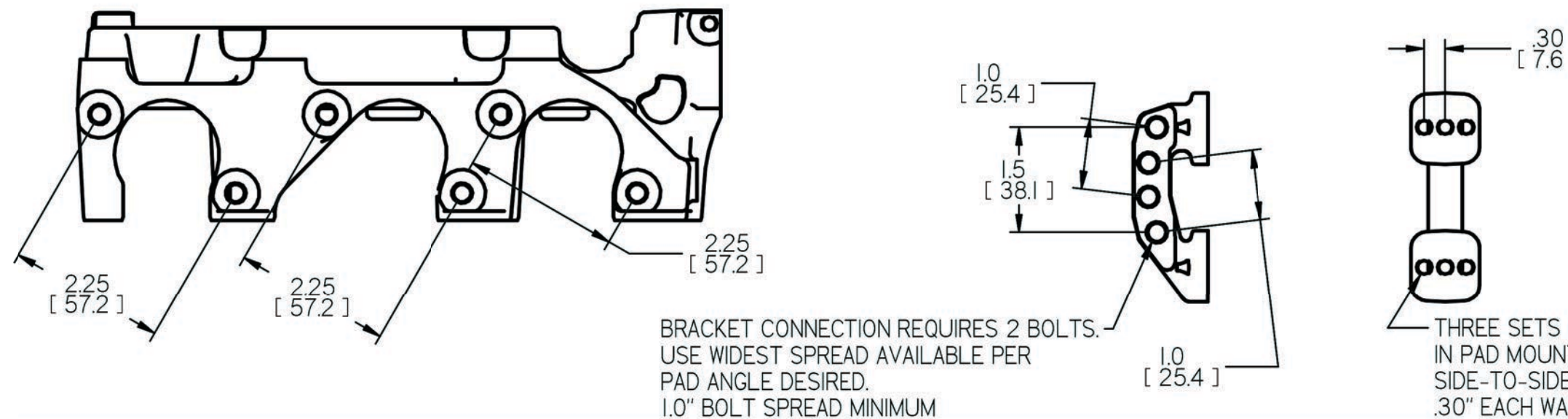

TILTON ENGINEERING, INC.		(805) 688-2353 FAX (805) 688-2745	
25 EASY STREET P.O. BOX 1787 BUELLTON, CALIFORNIA 93427 USA			
TITLE: PEDAL ASSEMBLY, UNDERFOOT, 3 PEDAL, INSTALLATION DRAWING			
DRN BY LUND	CHKD WAHL	SCALE 1:2	DWG 6055
P/N 72-616	DATE 6/20/2014	SHEET 1 OF 1	REV NC

\*This document contains proprietary information of TILTON ENGINEERING, INC., and its receipt or possession does not convey the rights to reproduce, disclose its contents, or to manufacture, use or sell anything it may describe. Reproduction, disclosure, or use without specific written authorization of TILTON ENGINEERING, INC. is strictly forbidden.\*

**TILTON ENGINEERING**